

SOLID STATE RELAY(SSR)

10 MH AC440V 10A~40A (DC/AC Type)

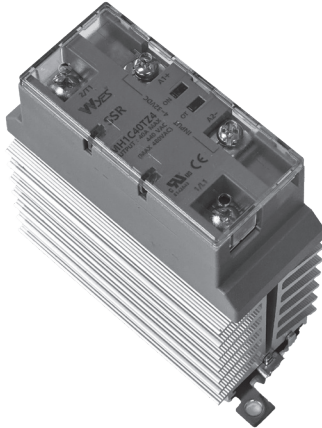

● DIN 방열판일체형(SSR/Heat Sink Type)



● Features

- 방열판 일체형 구조로 설계되어 우수한 열 전도성과 컴팩트한 설치가 가능합니다.
- T-TYPE 모델은 방열판 온도 상승 시 자동으로 출력을 차단하여 기기의 과열을 방지합니다.
- 단자 보호 커버를 채용하여 분실 우려가 없고, 외부 접촉으로 인한 안전사고를 예방합니다.
- UL508 규격을 준수하여 설계되었으며, 산업용 환경에서도 뛰어난 안전성과 신뢰성 제공합니다.
- It is designed with an integrated heat sink structure for excellent thermal conductivity and compact installation.
- The T-TYPE model prevents overheating of the device by automatically shutting off the output when the heat sink temperature rises.
- Terminal protection covers are employed to prevent loss and safety accidents caused by external contact.
- Designed to comply with the UL508 standard, it provides excellent safety and reliability in industrial environments.

● Specifications

MODEL		MH1C10 / 15 / 25 / 40TZ4				MH1C10 / 15 / 25 / 40TR4			
I N P U T	Rated Control Voltage	4~32VDC							
	Maximum Input Voltage	32VDC							
	Rated Control Current	15±3mA							
	Turn Off Voltage	1.4VDC							
O U T P U T	Load Voltage	90~480VAC							
	Non Repetitive Peak Voltage	1200VAC							
	Frquency	50/60HZ							
	Rated Load Current	10A	15A	25A	40A	10A	15A	25A	40A
	Surge Current 60HZ (8.3ms Non Repetitive)	170A	170A	260A	420A	168A	168A	260A	420A
	Surge Current 50HZ (10ms Non Repetitive)	160A	160A	250A	400A	160A	160A	250A	400A
	Contact Voltage Drop	1.27V	1.35V	1.36V	1.43V	1.27V	1.35V	1.36V	1.43V
Leakage Current	10mA at the 440Vac								
G E N E R A L	Dielectric Strength	2500VAC for 1Minute							
	Insulation Resistance	DC 500V 100MΩ							
	Response Time	Z4 : 8.3±1ms				R4 : 1±1m			
	Vibration Resistance	10~55~10HZ, peak amplitude 0.35mm (peak-to-peak amplitude 0.70mm) (Installed on Din-rail)							
	Shock Resistance	300m/s ² (Installed on Din-rail)							
	Circuit Control	Z4 : Zero Cross Type				R4 : Random Cross Type			
	Temperature Sensor(85°C)	O							
	Operating Temperature	-30~80°C							
	Storage Temperature	-30~80°C							
	Ambient Humidity	45~85°C RH							
	Safety Standards	Z4 :				R4 :			
	Load Category	LC A							
	Protection Rating (IP Rating)	IP20							
	Pollution Degree	2							
Weight(Heatsink 제외)	10A	0.27kg							
	15A	0.33kg							
	25A	0.35kg							
	40A	0.36kg							

SOLID STATE RELAY(SSR)

WYES®
무접점전자릴레이

10 MH AC440V 10A~40A (DC/AC Type)

UL US CE RoHS

● Dimension

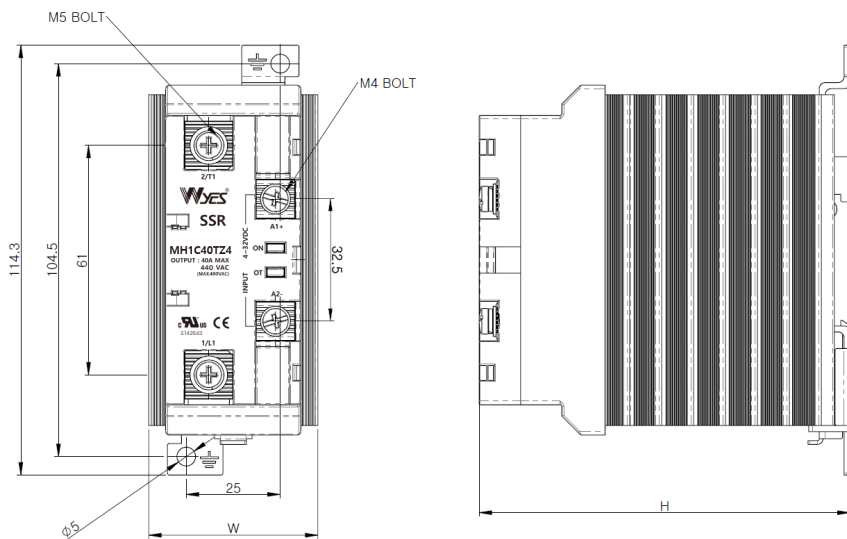

Current	10A	15A	20A	40A
H(높이)*W(폭)	73.3*38.2mm	87.2*38.2mm	98.7*38.2mm	98.7*45mm

● Terminal

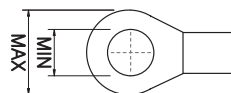

Input Ter : Max 10, Min 4
Output Ter : Max 12, Min 5

● Torque

Input Ter : 1.3~1.5N(10~14Kgf.cm)
Output Ter : 2.1~3.0N(15~25Kgf.cm)

● Load Current Curve

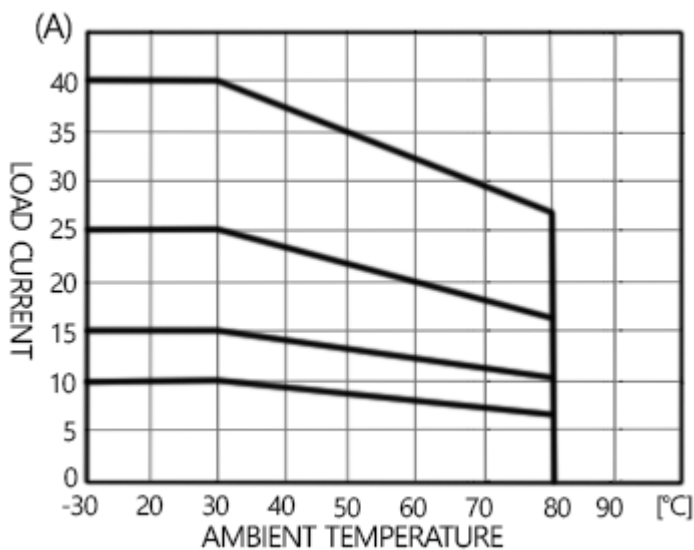

● Block Diagram

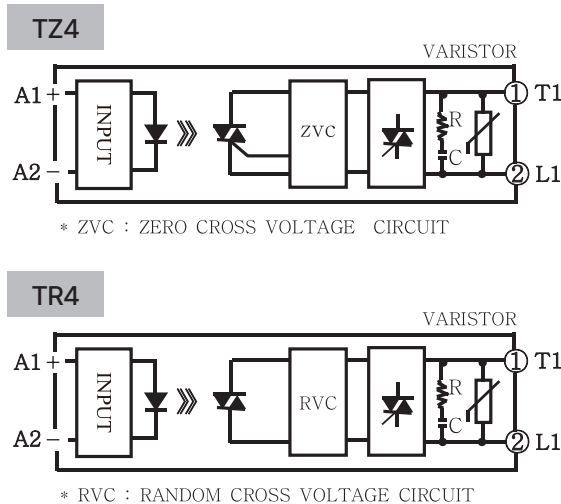

● Front Part Name

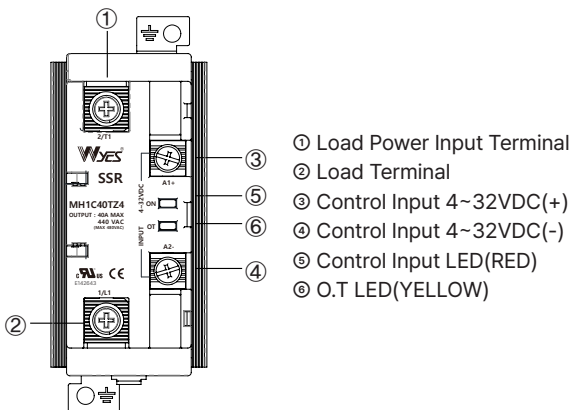

● Application Circuit

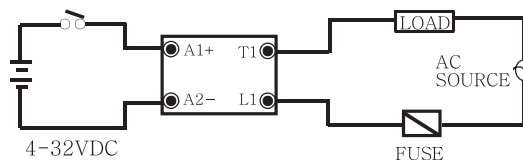

TRANS=무접점 전자릴레이
 REACTOR=리액터
 SSR=무접점 전자릴레이
 TPR=전력조정기
 SMP=스위칭파워
 NF=노이즈필터
 HF=하모닉필터
 SPD=서지보호기
 RELAY=보호계전기
 ELD=LED=냉각기
 ZCT=영상변류기
 METER=판넬메타
 CT=계기용변성기
 SHUNT=선트팬