

NOISE FILTER

3Ø 250V 고급형 High Quality Type

UL 인증



● Features

- 2 Mounting Option
 - WYF****D : Din Rail Mounting
 - WYF**** : Screw Mounting
 - Wide Band : High Attenuation
 - Band Width : 150KHz ~ 30MHz
 - Low Leakage
 - RoHS Compliant
 - KC(안전인증)
- Approved by HH03009-10002C

● Specifications

ITEM	MODEL	SYMBOL	WYFT05T1B (D)	WYFT10T1B (D)	WYFT15T1B (D)	WYFT20T1B (D)	WYFT30T1B (D)
Rated Voltage	V		250				
Rated Current	A		5	10	15	20	30
Frequency	Hz		50 / 60				
Dielectric Withstand	V		1500VAC or 2250VDC for 1 minute(Line-Case)				
Insulation Resistance	M.Ω		500				
Leakage Current	mA		0.8				
Operating Temperature	°C		-25°C ~ +100°C [Refer to Derating Curve TYPE-2]				
Operating Humidity	RH		35 ~ 85%RH				
Weight	kg		0.5				

※ Derating Curve of page 519

● Circuit Diagram

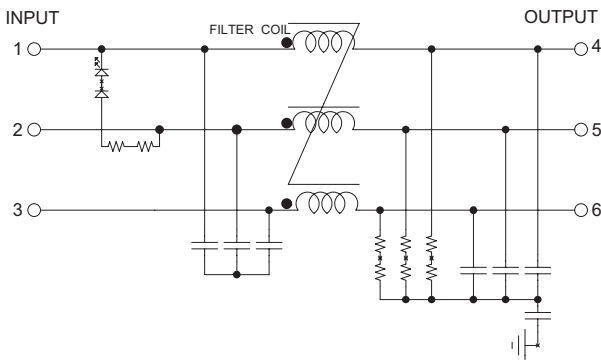

● Terminal

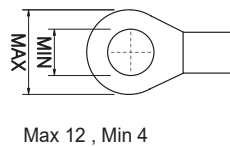

● Characteristics

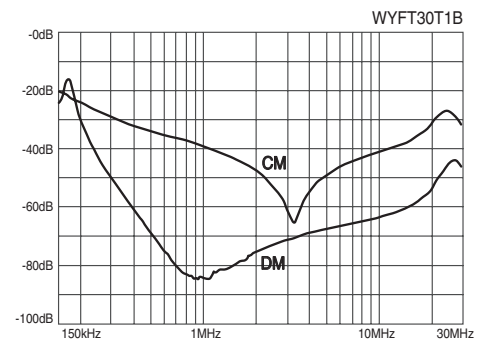
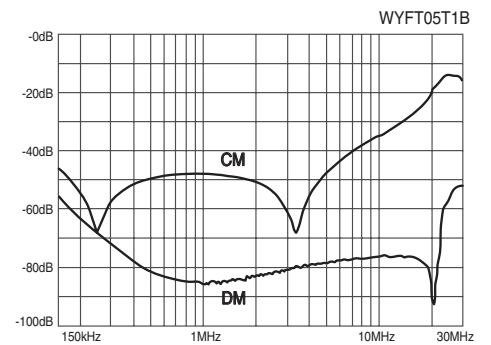

● Dimension

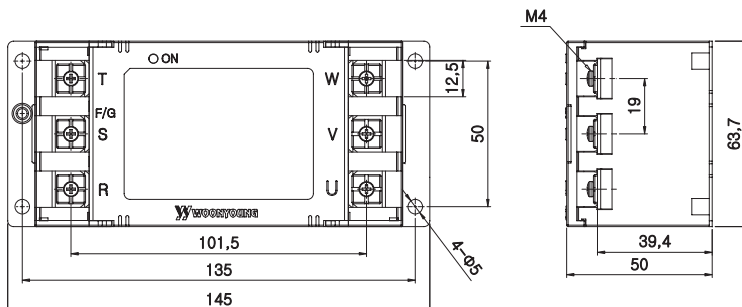

● Characteristics

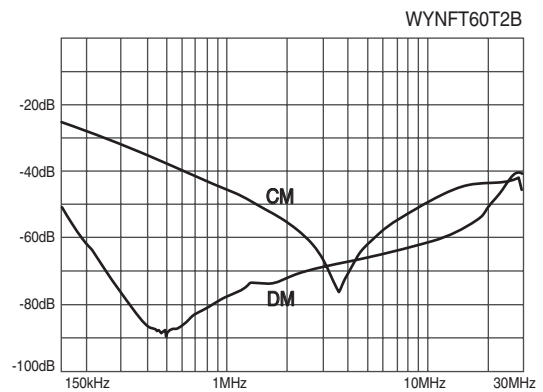
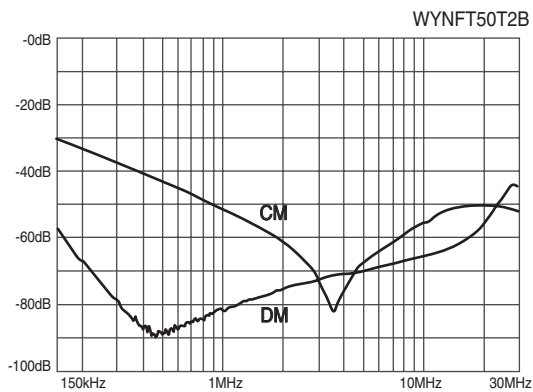
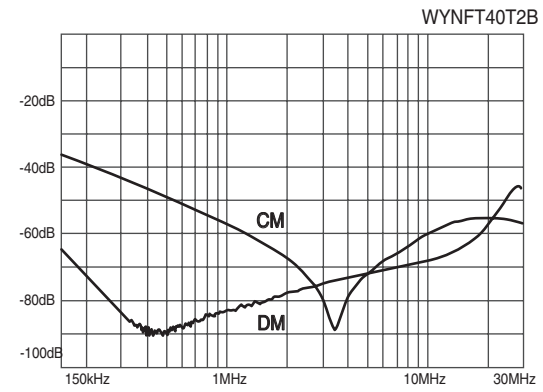
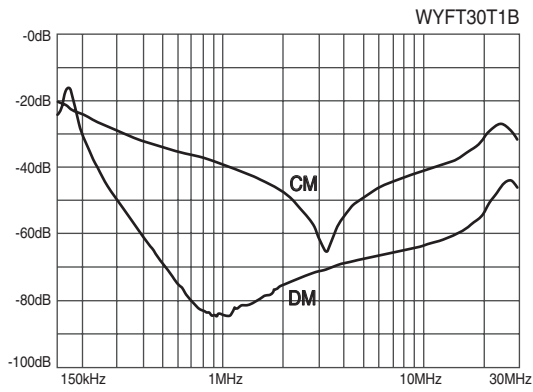
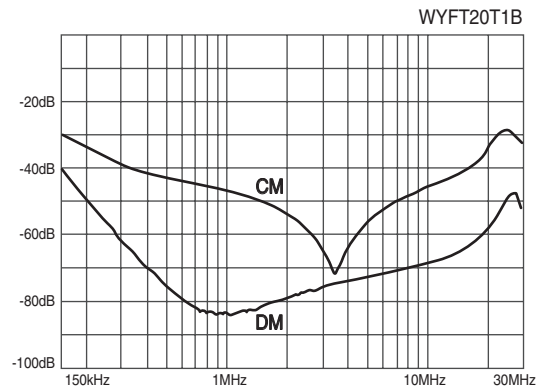
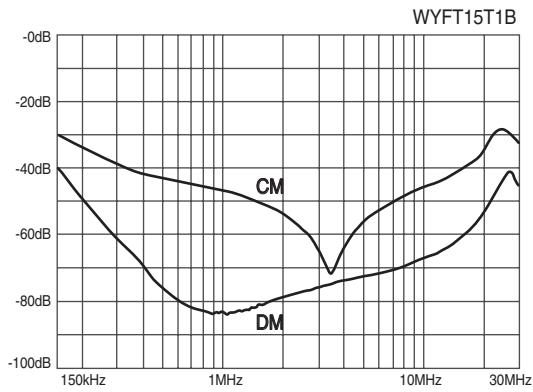
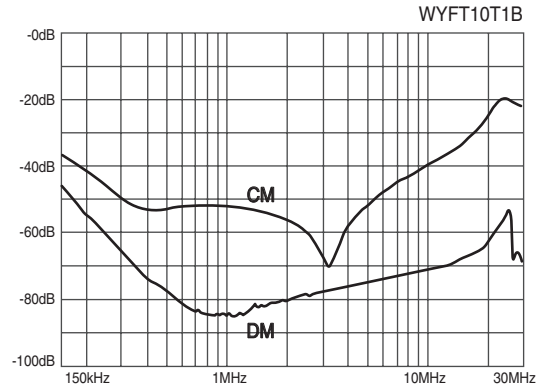
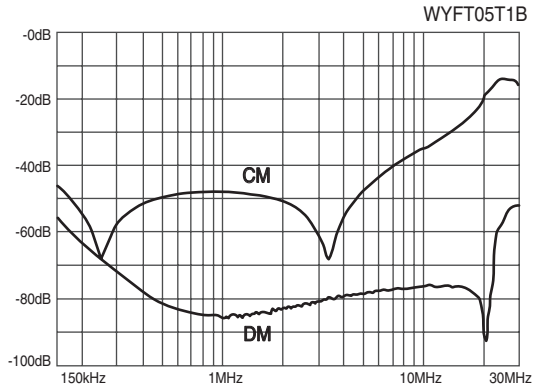

※ CM : Common mode, DM : Differential mode

● Characteristics

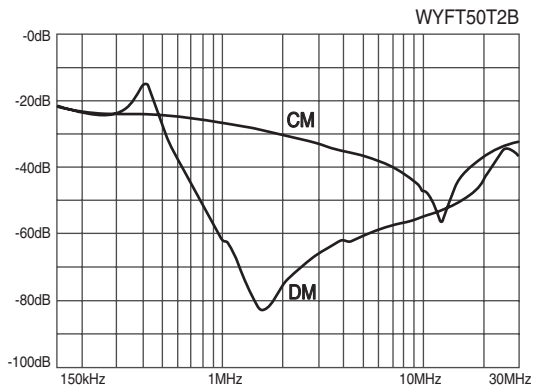
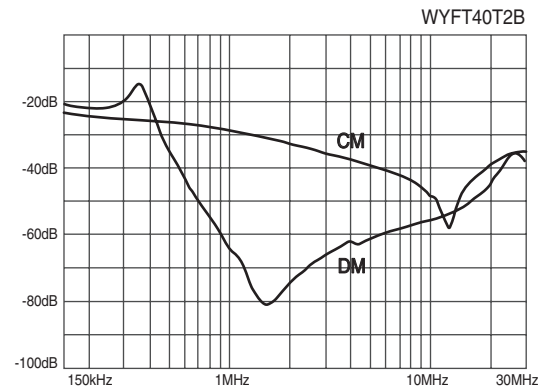
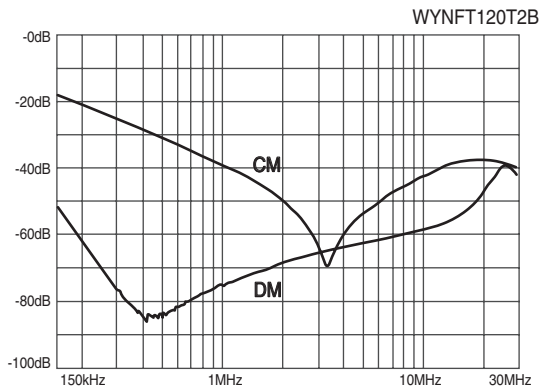
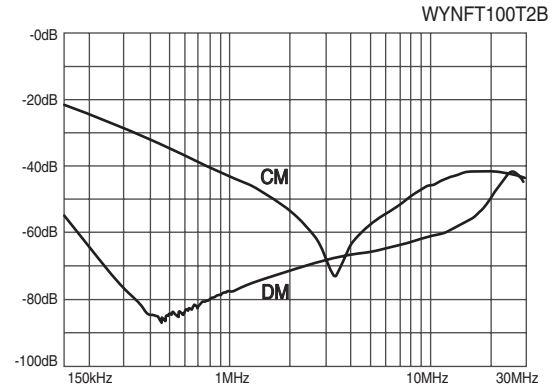
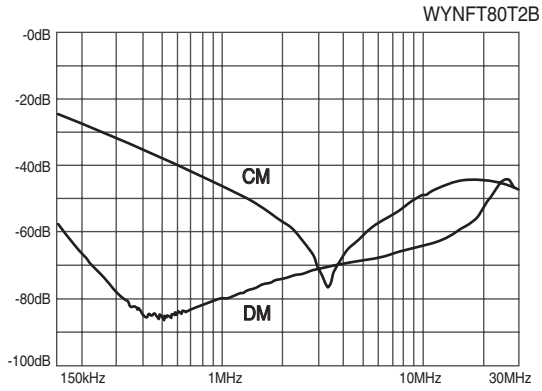

※ CM : Common mode, DM : Differential mode

트랜스포머
REACTOR
리액터
무정전압 레일
SSR
전력조정기
TPR
스위칭파워
SMP
S
노이즈 필터
H/F
하모닉 필터
S
서지보호기
SPD
R
보호계전기
RELAY
E
누전경보기
LD=GF
R
영상변류기
ZCT
M
판넬메타
ETER
계기용변성기
CT=VT
S
선트랜
HUNT=FA
N

● Characteristics

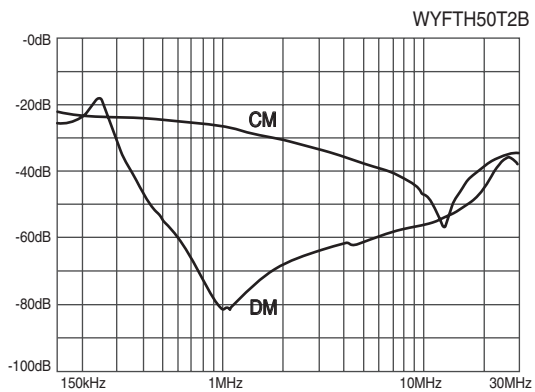
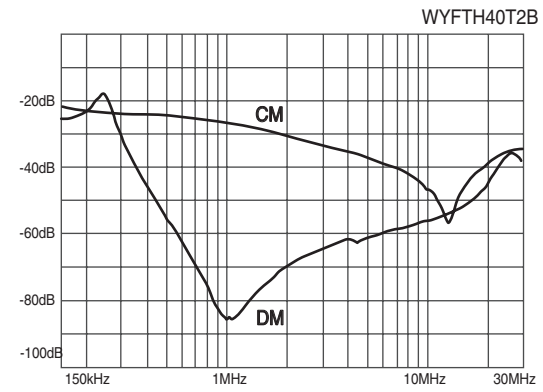
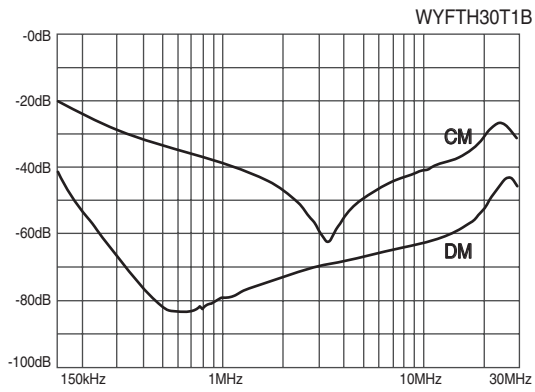
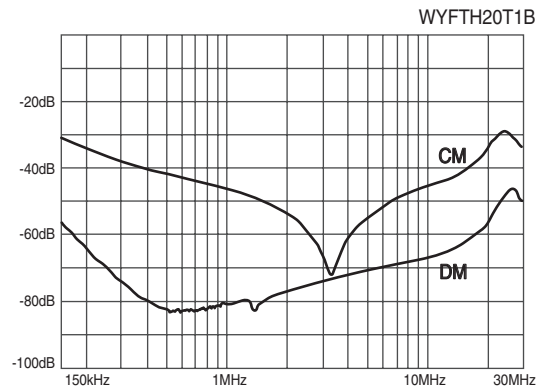
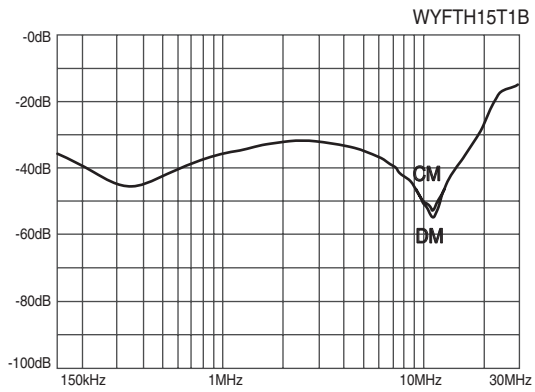
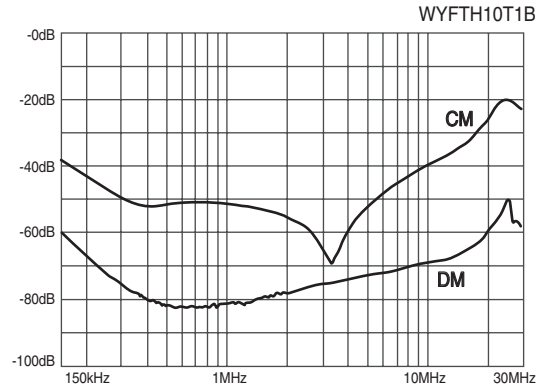
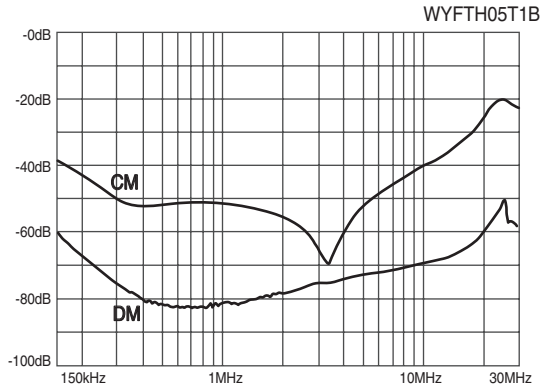

※ CM : Common mode, DM : Differential mode