

S. M. P. S

(Switching Mode
Power Supply)

EXPLANATION

ORDER

1. GENERAL FUNCTION	5-3
2. ELECTRIC CHARACTER	5-3
3. INSULATION	5-3
4. MOUNTING MEATHOD	5-6
5. OUTPUT TERMINAL WIRING	5-6
6. THE EXPECTED LIFE SPAN AND THE TEMPERATURE OF SURROUNDINGS	5-7
7. LIFE CYCLE AND TROUBLE	5-7
8. SMPS EXPLANATION	5-8
9. MODEL EXPLANATION	5-8
10. SPEC.	5-9
11. S.M.P.S MEATHOD OF MOUNTING.....	5-10
12. BLOCK DIAGRAM.....	5-13
13. SHAPE EXPLANATION	5-15

1. GENERAL FUNCTIONS AND CHARACTERISTICS

- 1) S.M.P.S is the device which supplies the necessary DC source by transforming AC source, We produce it by using three methods flyback method (15WATT,30WATT,50WATT) forward convertor method (75WATT,100WATT,200WATT) and half bridge method.(300WATT)
- 2) We use standardized goods or the same level as the main raw-material and components of or products they are not only up to U/L or CSA standard but also attached good to endure shakes and shocks.
- 3) We use FR4, 1.6t for P.C.B and the inside and outside heat-sink and case are made of a particular aluminum very strong against heat. We designed them for protection against heat by natural convection current. (When more than 300WATT it is protected against heat by force)

2. ELECTRIC CHARACTERISTICS

1) Input condition

I) Input voltage

There are three type of input voltage ,Free voltage, Auto selector, and selector type

Input type	Model (Output watt)	Remark
Free voltage	15WATT, 30WATT	85 ~ 264VAC
Selector	50WATT over model	85 ~ 132VAC 170 ~ 264VAC Selector

※ Every product contains a warning paper about input voltage ,excepting goods ordered.

II) Power input

"WYES" 15W ~ 30W power supply works on free voltage in AC85 - 264V 50WATT and over power supply works in the selected voltage by inner jumper. See the figure.

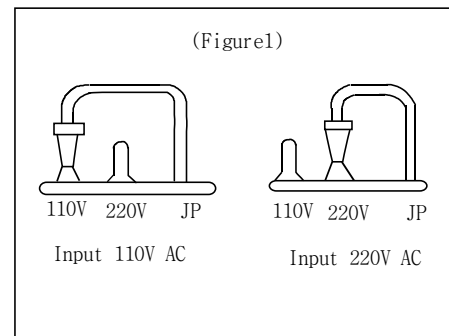

III) Input current

Our product is a condenser input form rectifying alternating current input directly, there flows reactive current in smoothing condenser. Thus input voltage is caculated by following calculation formula

$$I_{in} = \frac{V_{out}}{V_{in} \times \cos\theta \times \eta}$$

I_{in} : Input current V_{in} : Input voltage,
 V_{out} : Output voltage
 $\cos\theta$: Power factor η : Efficiency

IV) Inrush current

A charging peak current flows in input smoothing - condenser when input is projected and the ammount of it is up to several times to tens times compared to input current of normal operate. You should consider this when choosing fuse or switch of input wire.

Our products are input 220VAC and the rush current is under 30A.

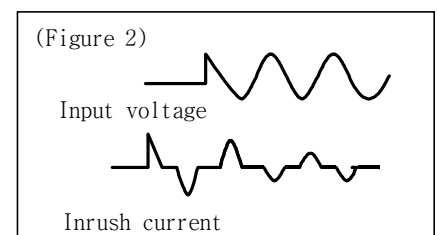

V) Input fuse

When the fuse in product open, there would be trouble with internal circuit or element.

Sometimes it's unable to recover just by changing fuse you should have our A/S. Our A/S period basic is equal to expected life span of the product. (Five years A/S is guaranteed)

VI) Input voltage regulation

When input voltage is changed (85~264VAC) under maximum output load regulation of output voltage is under $\pm 0.4\%$.

VII) Continuous ON/OFF

If you practice input voltage ON/OFF over 100 times every 5 seconds, there will be no change in output.

2) Output condition

I) A variable extent of output voltage

MODEL	CH1	CH2	CH3	CURRENT
15 WATT	5%	X	X	10 %
30 WATT	5%	10%	X	10 %
50 WATT	5%	10%	X	10 %

※ output voltage is coordinated when the product is sent out, you had better use it without control. But when control is needed it should be restricted to 2% of output voltage.

II) O.V.P

When output voltage surpasses the standard O.V.P operates to break it automatically. If you project input again after elimination the load (the cause). It will operate again excepting the condition of intral product problem.

※ O.V.P voltage is fixed you should come our office for changing it.

III) O.C.P

When output load surpasses the standard, output is broken automatically, and when output becomes normal state it comes back automatically. (Output short circuit protection)

IV) Ripple noise

Measurement of ripple noise is done in output terminal of power regardless of the load, you connect 0.47 μ F film condenser with 47 μ F electrolytic condenser in a parallel way to both ends of osilloscope probe.

Ripple noise of our product is under output voltage $\times 1\%$ if osilloscope probe.

V) Off state leakage

On the condition of AC220V input, off state leakage, among inputs and cases is under 2mA respectively.

VI) Current derating

You should notice that output power changes according to the temperature of surroundings. Thus you should use our product after derating, output in the extent of 100% when the temperature is 50 $^{\circ}$ C and 30% when the temperature is 70 $^{\circ}$ C

3. INSULATION

1) Insulation resistance

INPUT : CASE, OUTPUT : CASE , INPUT : OUTPUT - DC 500V MEGA OVER 100Mohm

2) Insulation voltage

INPUT : CASE, INPUT : OUTPUT - AC1,500V/10mA 60SECS, OUTPUT : CASE - AC500V/10mA 60 SECS.

4. MOUNTING MEATHOD

1) Natural protection against heat

S.M.P.S shows very different effectiveness depending on conditions of protection against heat. You must take care of ventilation and protection against heat. Especially when you use more than one S.M.P.S you should keep enough space among them respectively

2) Forced protection against heat

You can promote the effectiveness by using fan or other devices of forced protection against heat

3) Mounting

Back side or side hanged is possible and there is extra bracket for hanged. It is packed when the product is over 75WATT. The product over 75WATT contains it but that of under 75WATT need extra money for it.

5. OUTPUT TERMINAL WIRING

(I) You should distribute wires seperately, if not the outside source voltage of input part will lead to output part.

(II) If you use it in output part by twisting short there will be noise-reduction effect.

(III) If you attach a small capacity condenser ,there will be a noise-reduction effect.

(IV) You had better fix FG terminal to GND, because it's use is for security or protection against noise, but in case you are using sash GND, you don't need to consider a counter plan

6. THE EXPECTED LIFE SPAN AND THE TEMPERATURE OF SURROUNDINGS

The expected life span of S.M.P.S changes depending upon the temperature of surroundings . Especially as to electrolytic condenser, the expected life span tends to be reduced to 1/2 as the temperature of surroundings rises 10°C more the temperature has a fatal effect on the life all our condenser are used in 105°C but input smoothing condenser ,we recommend that you should refer to. The temperature/ operating period graph of each condenser catalog. Our products satisfy following conditions

Operation temperature - 10°C ~ 50°C

Safe keeping temperature - 20°C ~ 85°C

Humidity - 30°C ~ 85°C

7. LIFE CYCLE AND TROUBLE

Next figure show you failure rate curve, express life cycle of product.

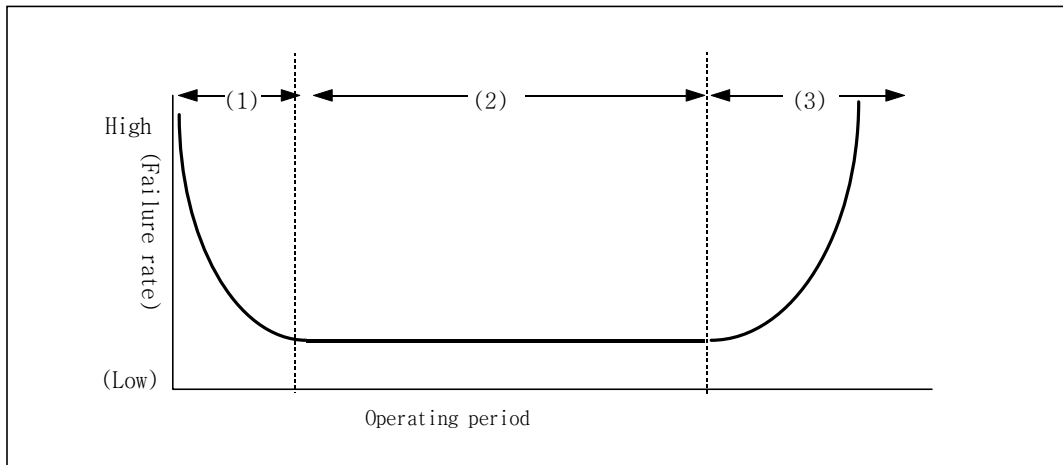

1) Initial trouble time

Manufacturer select parts carefully for prevention of initial trouble time, so after assembly, ageing enough and then ship goods. Therefore you use switching power in incidental trouble time.

2) Incidental trouble time

If it goes wrong at this time, it is because for actual term (Environment temperature, Mounting method, Ventilation, Vibration etc.)

3) Wear trouble time

There is wear trouble time as time passes by.

8. “ Wyes” SMPS MODEL INFORMATION

1) Characteristic

New wyes power supply series are the best products which these series units are used to secure high performance and reliability and are developed by creative technology.

You would have the more valued power supply..

2) Special features

- Low price
- High efficiency
- The same mounting the similar unit of competitors.
- FCC CLASS B
- Case covered mountable in either two side
- When power source attached possible inner tes with cover opened
- Wide full input range
 - ◆ 15 ~ 50 WATT : AC85 ~ 264V Free voltage
 - ◆ 75 WATT over : AC110/220V selectable by jumper.
- Input inrush current
- O.C.P - Foldback Current Limiting
- O.V.P - Over Voltage Clamp
- Low noise

9. ORDERING INFORMATION

■ W Y S P - 1 5 S 0 3 A

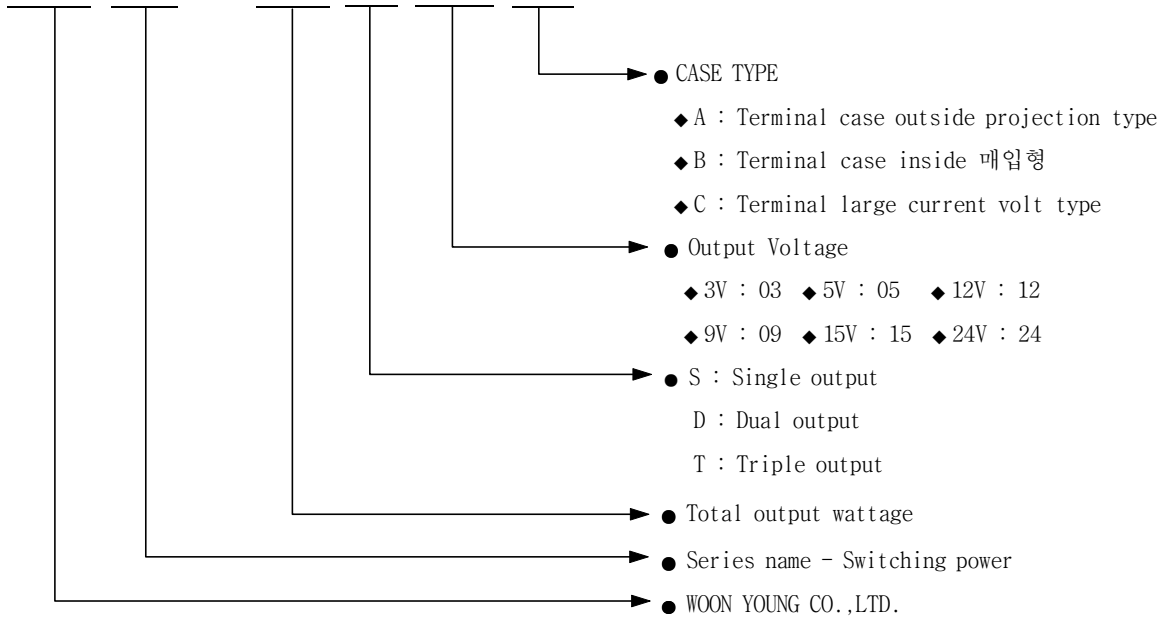

10. STANDARD SPECIFICATION

SECTION	ITEM	SYMBOL	RATING
Input	Phase	ϕ	Single
	Voltage	V	AC85 ~ 264, AC85 ~ 132/170 ~ 264
	Frequency	Hz	47 ~ 440
Output	Ajustable Voltage	%	10
	Line Regulation	%	0.4 Max (AC85 ~ 132/170 ~ 264)
	Load Regulation	%	1Max (0 ~ 100%)
	Temperature Coefficient	% / °C	0.02 (-5 ~ +50°C)
	RIPPLE NOISE	mvp/p	OUTPUT V× 1% + 50 (AC100MHz)
	DRIFT	mv	OUTPUT V× 0.5% +15/8H AFTER 1H
	Rise Up Time	ms	100 Max (+25°C)
Protection	Hold Up Time	ms	20 (+25°C)
	O. C. P		Fold Back Current Limiting
	O. V. P		V1 only 0V Clamp
	Input Inrush Current	A	15A(15W), 15A(30W), 35A(50W)
Environment	Operating Temperature	°C	0 ~ +50 (FULL LOAD)
	Storage Temperature	°C	-20 ~ +85
	Humidity	%	30 ~ 85
	Vibration		(5 ~ 10Hz) 10mm, (10 ~ 55Hz)2G
	Shock	G	10G
Isolation	Input - Output	V	AC500 (10mA) 1 Minute
	Input - Case	V	AC500 (10mA) 1 Minute
	Output - Case	V	AC500 (10mA) 1 Minute

■ OVER CURRENT CHARACTERISTICS

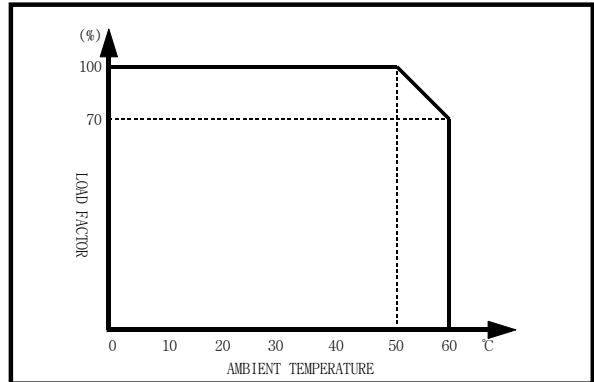
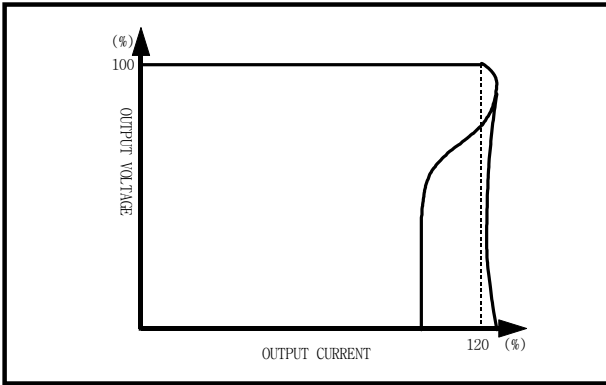

11. SWITCHING MODE POWER SUPPLY INSTALL AND MANUAL KEYPOINT

1) Manual key - point

The switching of the source of electric power occupies the heat too much, in this case getting to effect the life of power source and confidence. The important thing is concerned the radiated heat for insulation. The best way to reduce higher temperature is as follows

1. Ventications : The best way of ventication is using the converted wind
2. Direction : It is basic to install as converted wind
3. Distance : It is necessary to distance for using various power source
4. Thermal conduction : Very important for thermal conduction with heat sink to install.
5. Air cooling : To increase of cooling by using the fan

2) Manual direction

The range of using temperature of power shall be fixed to concern cooling by air, power heat sink for effect to install as a conversion, to place horizontal put the P.C.B to be plated compape with vertical to take place conversion temperature of the source of power is getting higher. The rate of loading at horizontal 60~80°C is going down to need the force air cooling to avoid over heating inside of smps.

그림1. 취부간격

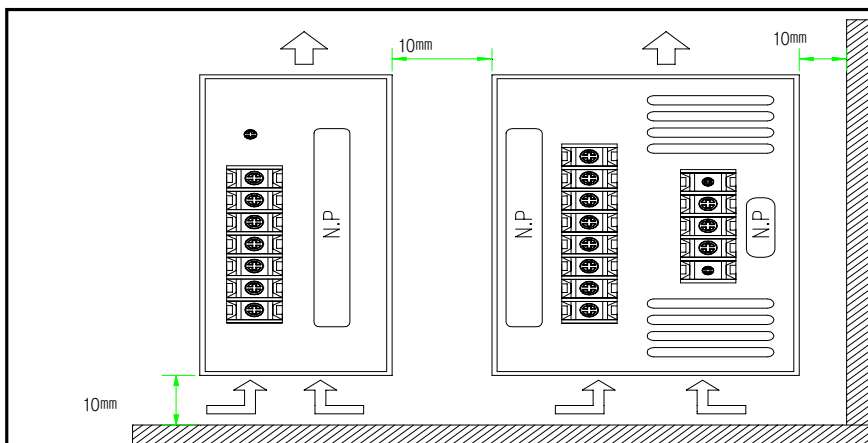

3) Method to handle by use of horizontal bracket

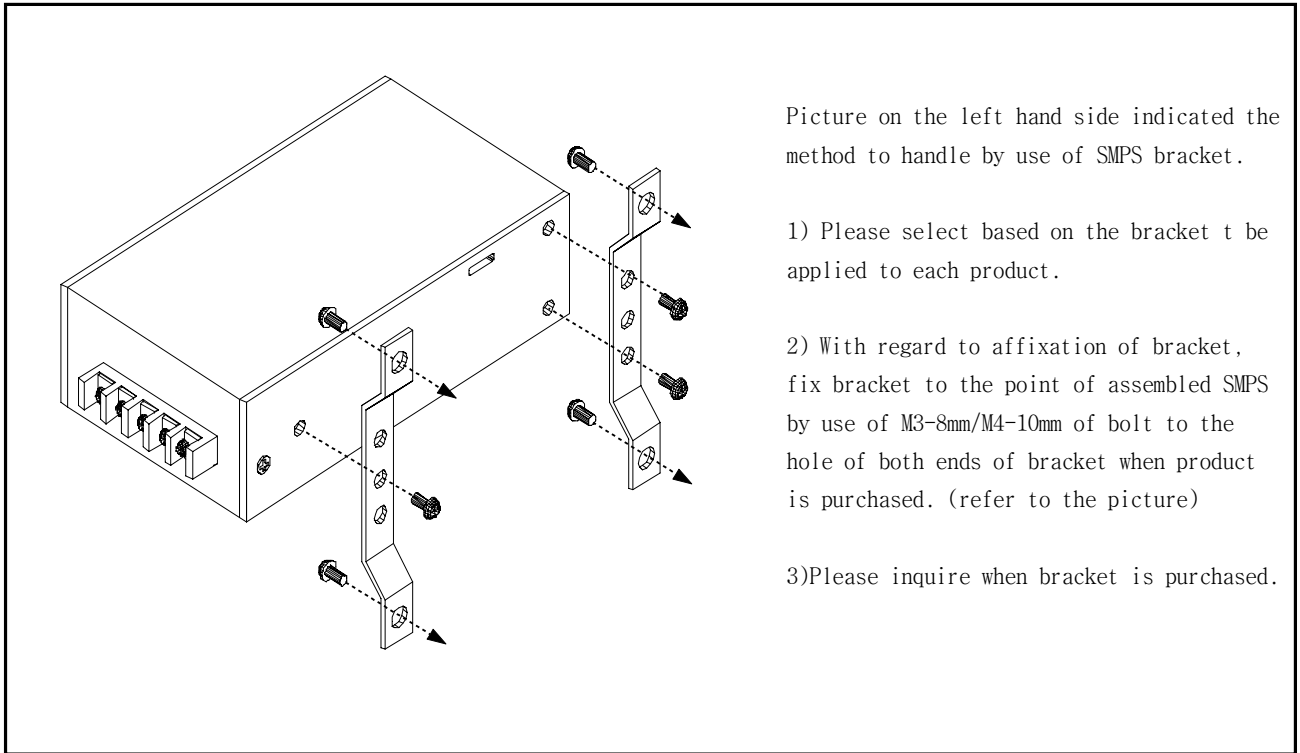

Specification	Applied model	Dimension
WYBRK - H1	WYSP-15W SERIES WYSP-30W SERIES WYSP-50W SERIES WYSP-75W SERIES	
WYBRK - H2	WYSP-100W SERIES WYSP-120W SERIES WYSP-150W SERIES	
WYBRK - H3	WYSP-200W SERIES WYSP-300W SERIES WYSP-600W SERIES WYSP-1000W SERIES WYSP-1200W SERIES WYSP-1500W SERIES	

4) Method to handle by use of vertical bracket

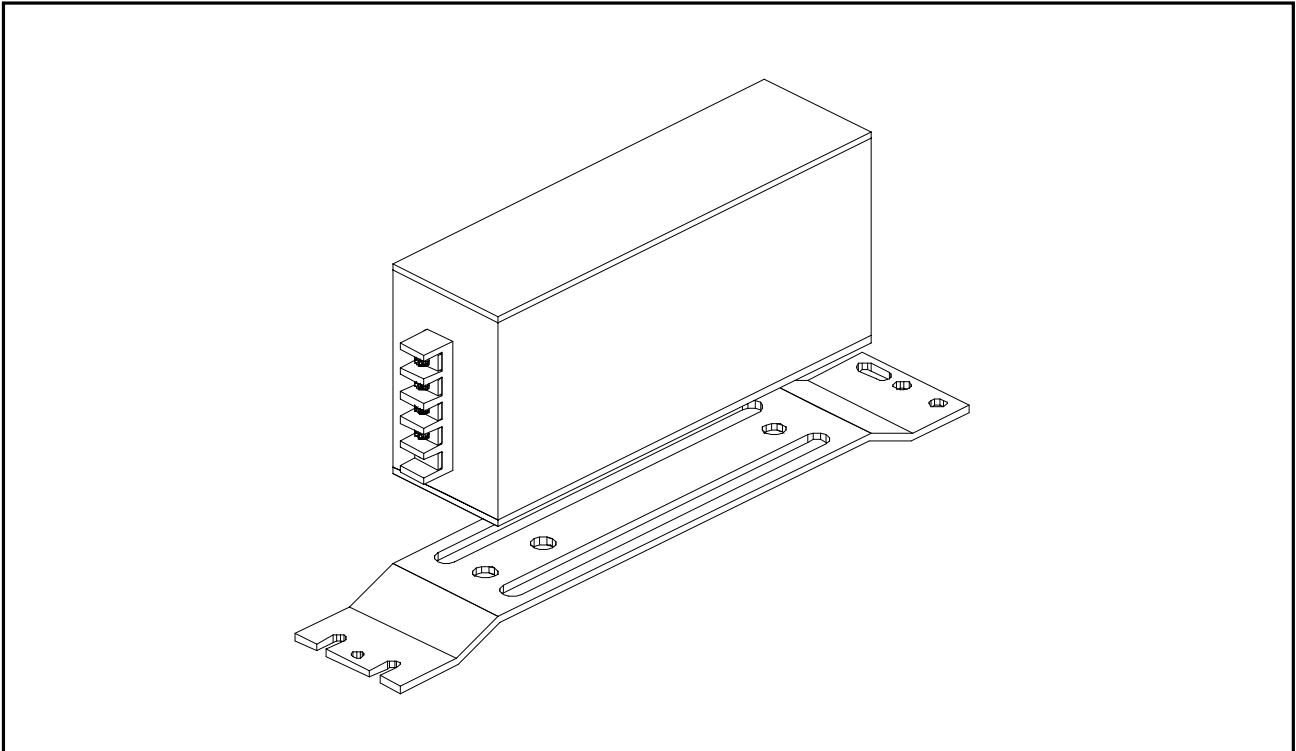

Specification	Applied model	Dimension
WYBRK - V1	WYSP-15W SERIES WYSP-30W SERIES WYSP-50W SERIES	
WYBRK - V2	WYSP-75W SERIES	
WYBRK - V3	WYSP-100W SERIES WYSP-120W SERIES WYSP-150W SERIES	

12. BLOCK DIAGRAM

■ Single output 100W over

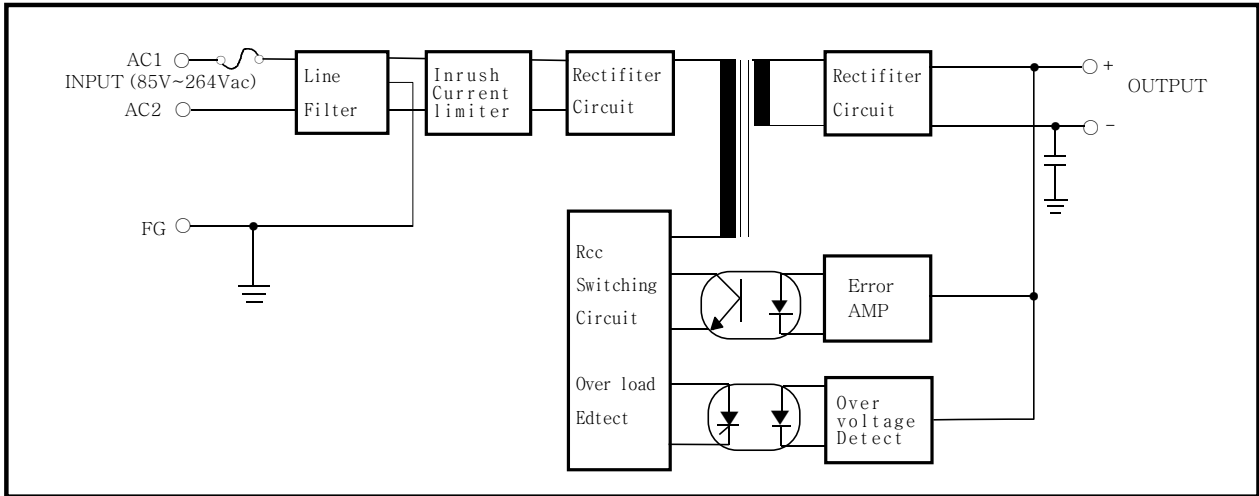

■ Single output 100W over

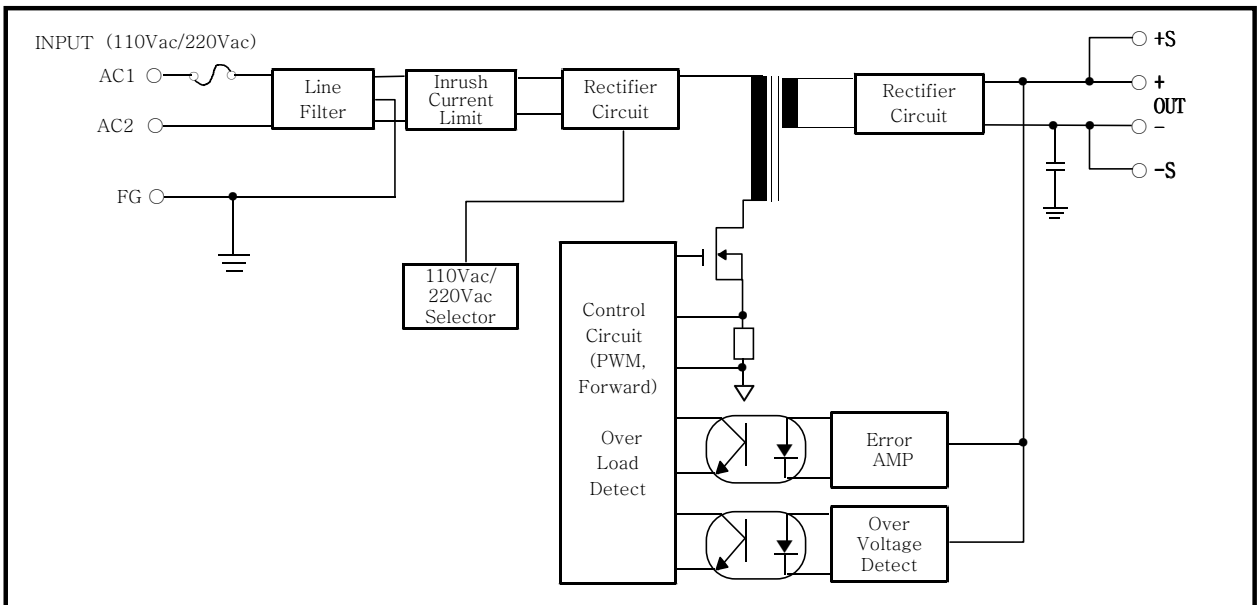

■ Single output 300W over

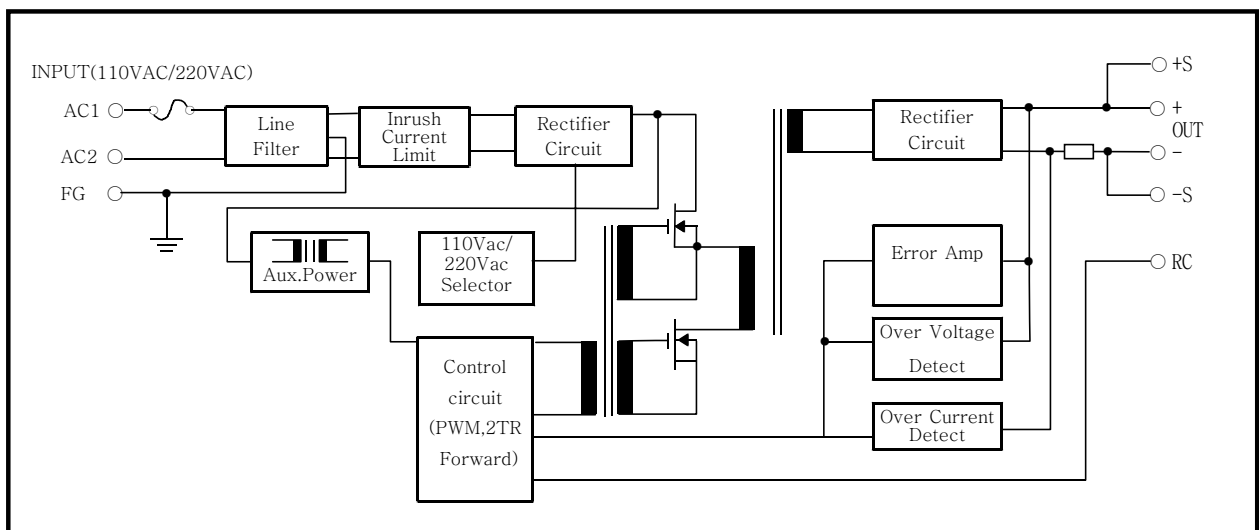

■ Dual output

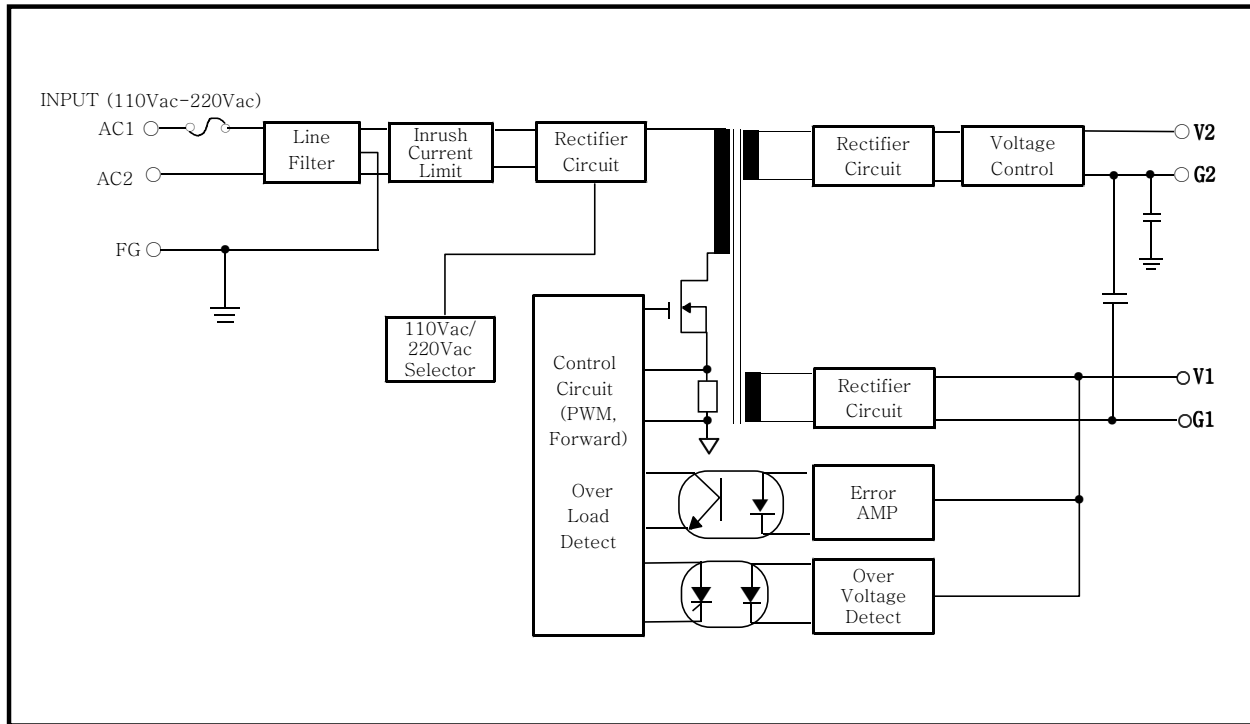

■ Triple output

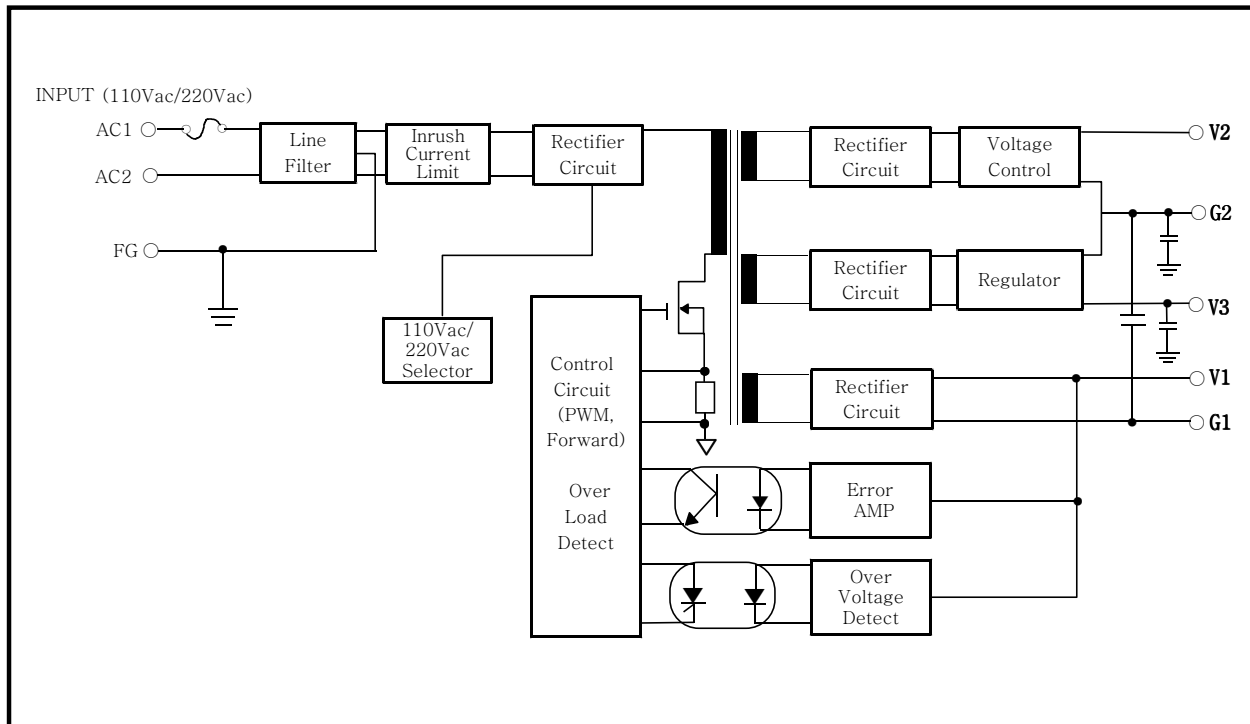

13. Outside model information

- Model to be applied : WYSP-15W SERIES, WYSP-30W SERIES, WYSP-50W SERIES

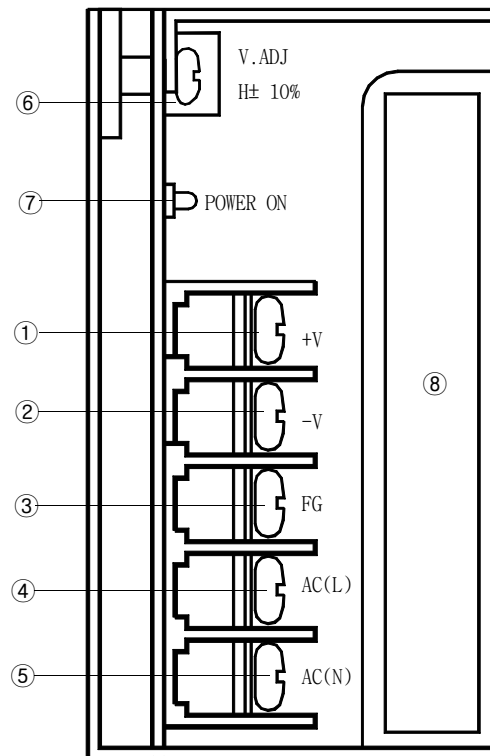

- ① + Output terminal
- ② - Output terminal
- ③ Frame ground
- ④ Ac input (L : Live line)
- ⑤ Ac input (N : Neutral line)
- ⑥ Variable volume of output voltage (regular voltage in a variable scope +/-10%)
- ⑦ Output mark LED (green)
- ⑧ T.N.P : Indicating specification of terminal

■ Model to be applied : WYSP-75W SERIES

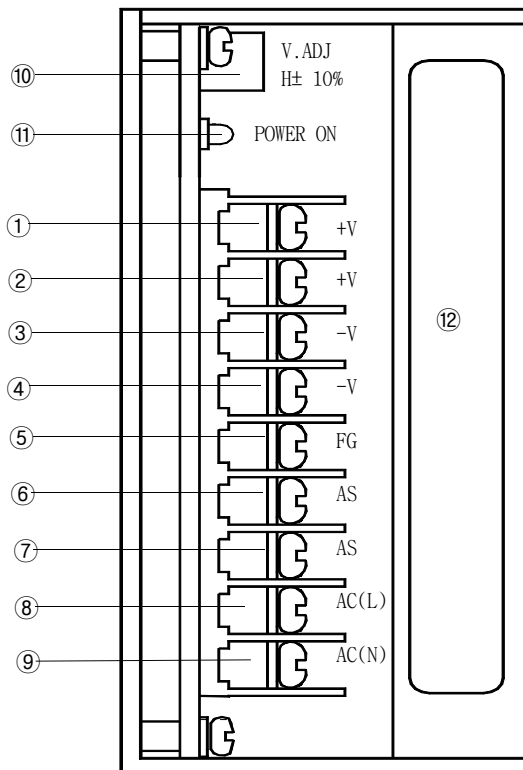

- ①, ② + Output terminal
- ③, ④ -Output terminal
- ⑤ Frame ground
- ⑥ AS : 110V/220V terminal
- ⑦ AS : 110V/220V terminal
(close-110V, open-220V)
- ⑧ Ac input (L : Live line)
- ⑨ Ac input (N : Neutral line)
- ⑩ Variable volume of output voltage (regular voltage in a variable scope +/-10%)
- ⑪ Output mark LED (green)
- ⑫ T.N.P : Indicating specification of terminal

■ Model to be applied : WYSP-100W SERIES , WYSP-120W SERIES, WYSP-150W SERIES

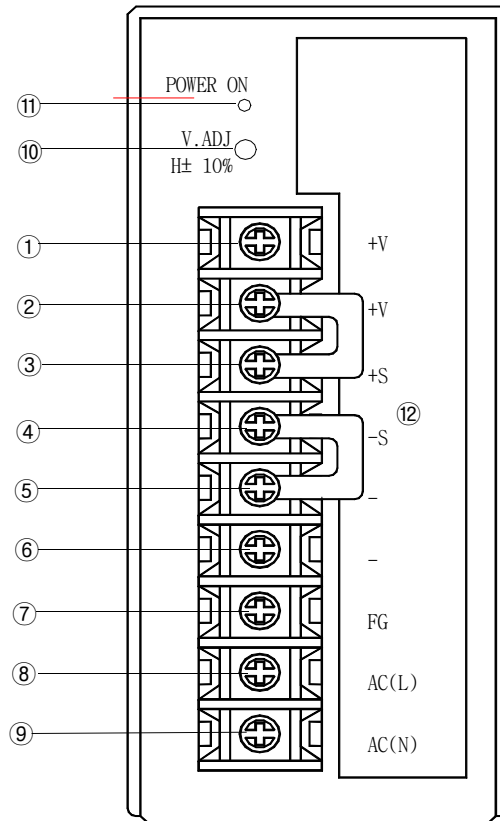

①, ② + Output terminal

③, ④ Remote sense (+S,-S)

when distance between SMPS and load is far, it compensates voltage of load is out of rated figure because of decrease of voltage between wiring.

⑤, ⑥ -Output terminal

⑦ Frame ground

⑧ Ac input (L : Live line)

⑨ Ac input (N : Neutral line)

⑩ Variable volume of output voltage (regular voltage in a variable scope +/-10%)

⑪ Output mark LED (green)

⑫ T.N.P : Indicating specification of terminal

■ Model to be applied : WYSP-200W SERIES

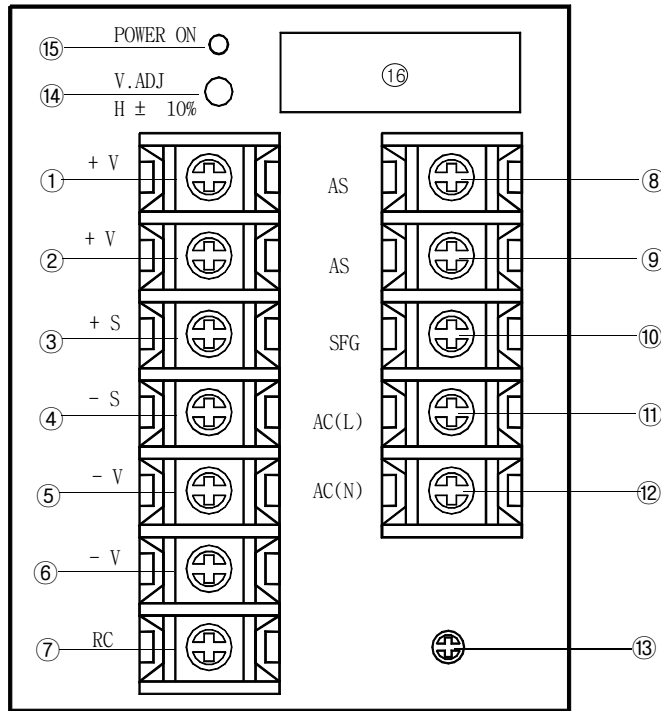

①, ② +Output terminal

③, ④ Remote sense(+S,-S) when distance between SMPS and load is far, it compensates voltage of load is out of rated figure because of decrease of voltage between wiring.

⑤, ⑥ -Output terminal

⑦ Remote on/off terminal (open : on, close : off)

When SMPS is on/off at the long distance, output is cut or output is intercepted because of external or internal reasons, this terminal resets SMPS to start.

⑧ AS : 110V/220V terminal

⑨ AS : 110V/220V terminal

(Close -110V, Open - 220V)

⑩ SPG : Safety ground

⑪ Ac input (L : Live line)

⑫ Ac input (N : Neutral line)

⑬ FG : Frame ground

⑭ Variable volume of output voltage (regular voltage in a variable scope +/-10%)

⑮ Output mark LED (green)

⑯ T.N.P : Indicating specification of terminal

■ Model to be applied : WYSP-300W SERIES

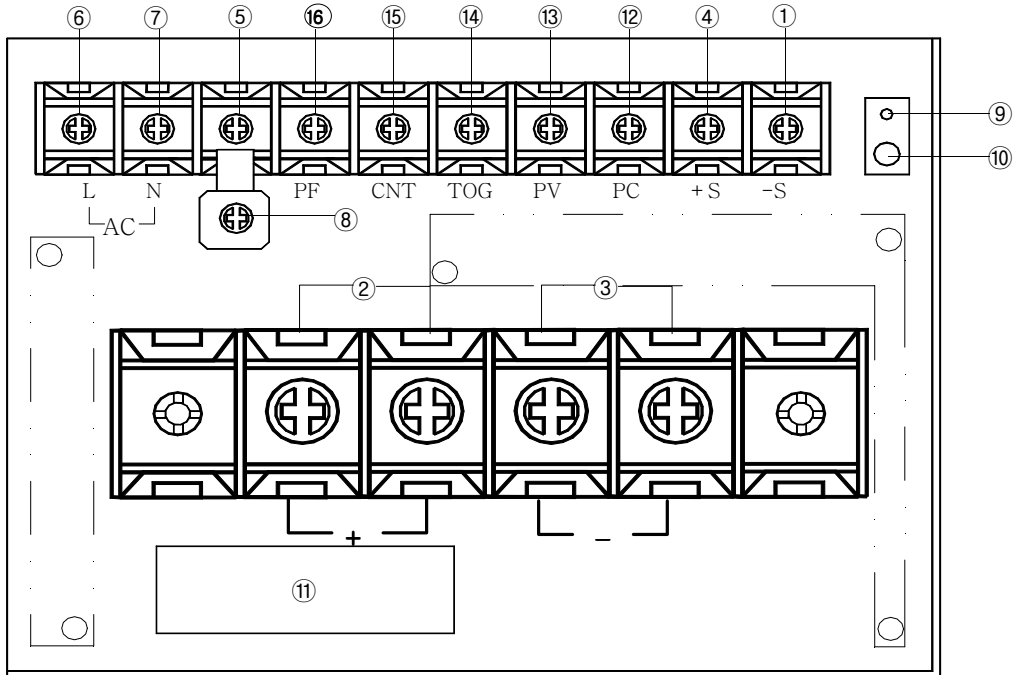

①, ④ Remote sense (+S,-S)

when distance between SMPS and load is far, it compensates voltage of load is out of rated figure because of decrease of voltage between wiring.

② + Output terminal

③ -Output terminal

⑤ SFG : Safety ground

⑥ Ac input (L : Live line)

⑦ Ac input (N : Neutral line)

⑧ F.G : Frame ground

⑨ Output mark LED (green)

⑩ Variable volume of output voltage (regular voltage in a variable scope +/-10%)

⑪ T.N.P : Indicating specification of terminal

⑫, ⑬ Terminal which links each SMPS when SMPS of two terminals is used in a parallel in case of parallel connection.

- Condition : output voltage must be within 0.1V.

- Wiring distance to the load must be same.

- It must be used within 80% of regular output.

⑭, ⑮ Remote ON/OFF Terminal (OPEN : ON, CLOSE : OFF)

When SMPS is on/off at the long distance, output is cut or output is intercepted because of external or internal reasons, this terminal resets SMPS to start.

⑯ Power fail signal out (Tog common)

When output is below specified figure, it searched and send signal to PF terminal based on the TOG terminal.

■ Model to be applied : WYSP-600W SERIES

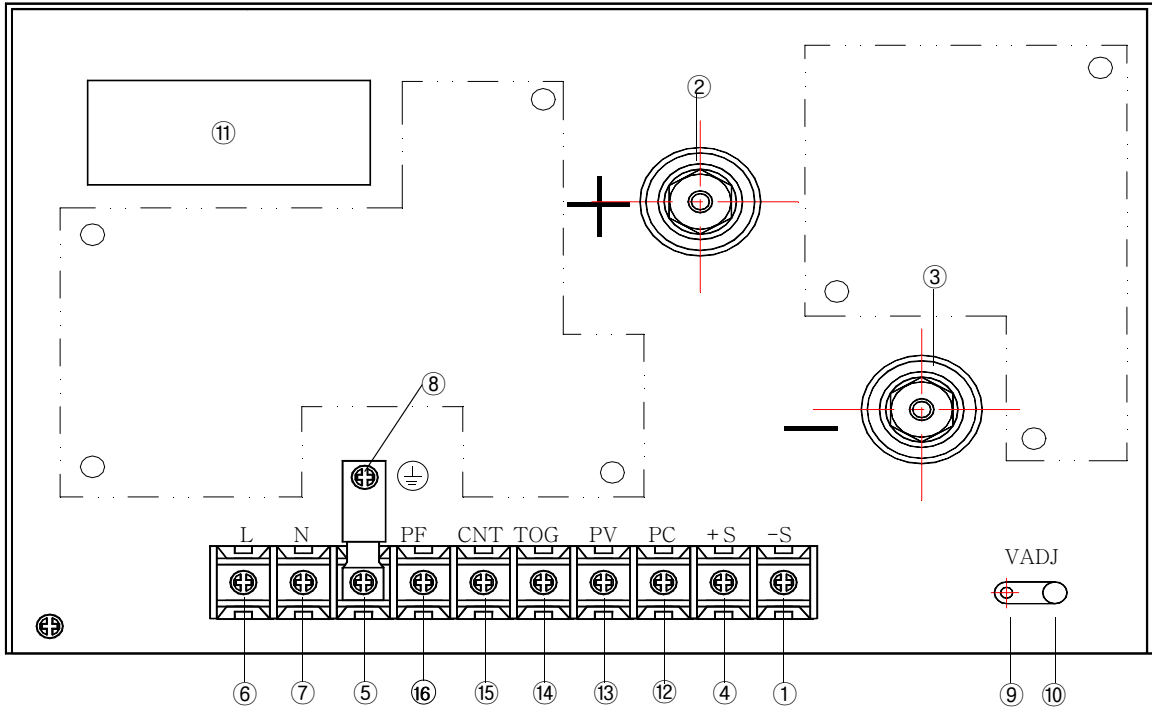

- ①, ④ Remote sense (+S,-S) when distance between SMPS and load is far, it compensates voltage of load is out of rated figure because of decrease of voltage between wiring.
- ② +Output terminal
- ③ - Output terminal
- ⑤ SFG : Safety ground
- ⑥ Ac input (L : Live line)
- ⑦ Ac input (N : Neutral line)
- ⑧ F.G : Frame ground
- ⑨ Output mark LED (green)
- ⑩ Variable volume of output voltage (regular voltage in a variable scope +/-10%)
- ⑪ T.N.P : Indicating specification of terminal
- ⑫, ⑬ Terminal which links each SMPS when SMPS of two terminals is used in a parallel in case of parallel connection.
 Condition : output voltage must be within 0.1V.
 - Wiring distance to the load must be same.
 - It must be used within 80% of regular output.
- ⑭, ⑮ Remote ON/OFF Terminal (OPEN : ON, CLOSE : OFF)
 When SMPS is on/off at the long distance, output is cut or output is intercepted because of external or internal reasons, this terminal resets SMPS to start.
- ⑯ Power fail signal out (TOG common)
 When output is below specified figure, it searched and send signal to PF terminal based on the TOG terminal.

■ Model to be applied : WYSP-1200W SERIES, WYSP-1500W SERIES

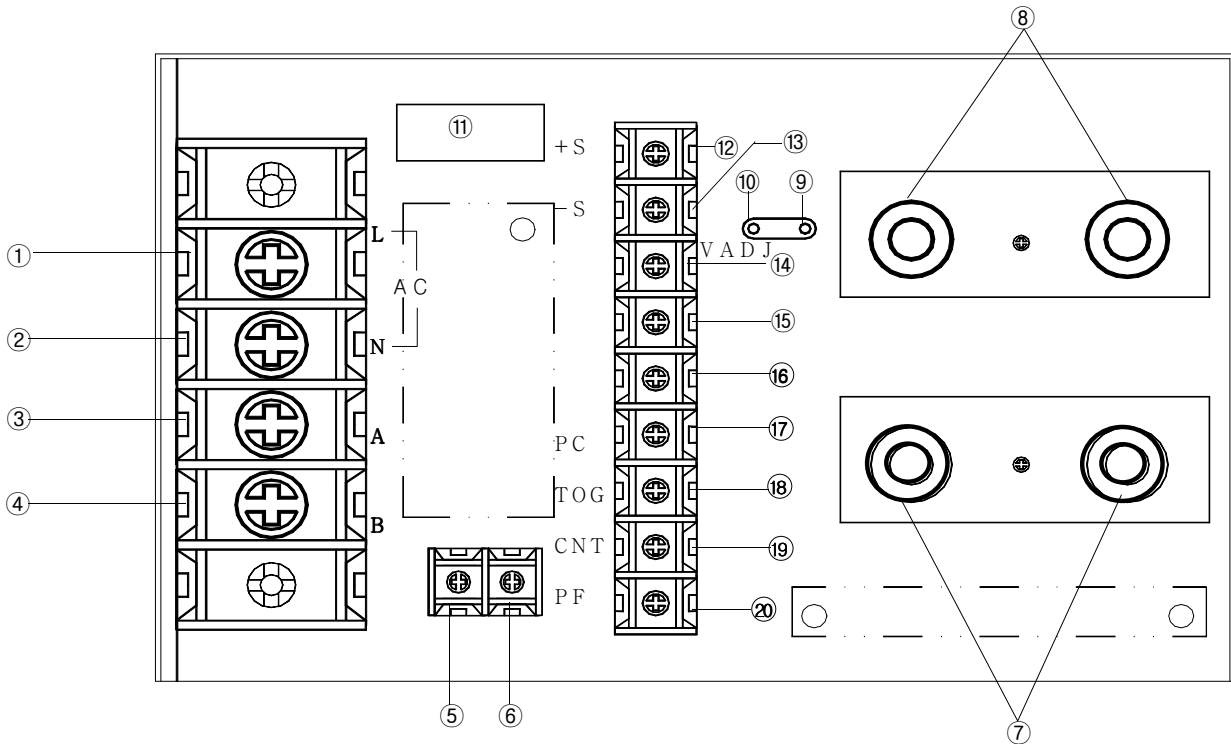

- ① , ② Ac input (L : Live line, N : Neutral line)
- ③ , ④ Input convert terminal of 110V/220V (SHORT : 110V, OPEN : 220V)
- ⑤ SFG : Safety ground
- ⑥ F.G : Frame ground
- ⑦ - Output terminal (M8 SCREW 2EA)
- ⑧ + Output terminal (M8 SCREW 2EA)
- ⑨ Variable volume of output voltage (regular voltage in a variable scope +/-10%)
- ⑩ Output mark LED (green)
- ⑪ T.N.P : Indicating specification of terminal
- ⑫,⑬ Remote sense (+S, -S)

when distance between SMPS and load is far, it compensates voltage of load is out of rated figure because of voltage decrease between wiring.

- ⑭,⑮,⑯ NC

- ⑰ Terminal which links each SMPS when SMPS of two terminals is used in a parallel in case of parallel connection.

Condition : output voltage must be within 0.1V.

- Wiring distance to the load must be same.
- It must be used within 80% of regular output.

- ⑱ , ⑲ Remote on/off terminal (OPEN : ON, CLOSE : OFF)

When SMPS is on/off at the long distance, output is cut or output is intercepted because of external or internal reasons, this terminal resets SMPS to start.

- ⑳ Power fail signal out (TOG common)

When output is below specified figure, it searched and send signal to PF terminal based on the TOG terminal.

■ SWITCHING POWER SUPPLY

◆ WYSP-SERIES

SINGLE OUTPUT

OUTPUT VOLTAGE (V)	OUTPUT AMPS (A)	OUTPUT WATTS (W)	MODEL	INPUT VOLTAGE (V)	FUNCTION							DIMENSION W× H× D (mm)	PAGE
					OCP	OVP	V-SENS	R-C	CB	FAN	ALARM		
5	3.0	15	WYSP - 15S05B	AC 85 ~ 264	○							64× 97.5× 32	5-30
	6.0	30	WYSP - 30S05B		○	○						79× 98× 37	5-31
	10.0	50	WYSP - 50S05B	AC85 ~ 132 / 170 ~ 264	○	○						83× 125× 40	5-32
	15.0	75	WYSP - 75S05B		○	○						96× 135× 40	5-33
	20.0	100	WYSP - 100S05A		○	○	○					105× 205× 46	5-34
	24.0	120	WYSP - 120S05A		○	○	○					105× 205× 46	5-35
	30.0	150	WYSP - 150S05A		○	○	○					105× 205× 46	5-36
	40.0	200	WYSP - 200S05A		○	○	○					97× 192× 80	5-37
	60.0	300	WYSP - 300S05A		○	○	○	○	○	○	○	120× 190× 92	5-38
	120.0	600	WYSP - 600S05C		○	○	○	○	○	○	○	190× 200× 92	5-39
	240.0	1200	WYSP - 1200S05C		○	○	○	○	○	○	○	200× 300× 97	5-40
	300.0	1500	WYSP - 1500S05C		○	○	○	○	○	○	○	200× 300× 97	5-41
9	1.7	15	WYSP - 15S09B	AC 85 ~ 264	○							64× 97.5× 32	5-30
	3.3	30	WYSP - 30S09B		○	○						79× 98× 37	5-31
	5.6	50	WYSP - 50S09B	AC85 ~ 132 / 170 ~ 264	○	○						83× 125× 40	5-32
12	1.3	15	WYSP - 15S12B	AC 85 ~ 264	○							64× 97.5× 32	5-30
	2.5	30	WYSP - 30S12B		○	○						79× 98× 37	5-31
	4.2	50	WYSP - 50S12B	AC85 ~ 132 / 170 ~ 264	○	○						83× 125× 40	5-32
	6.3	75	WYSP - 75S12B		○	○						96× 135× 40	5-33
	8.3	100	WYSP - 100S12A		○	○	○					105× 205× 46	5-34
	10.0	120	WYSP - 120S12A		○	○	○					105× 205× 46	5-35
	12.5	150	WYSP - 150S12A		○	○	○					105× 205× 46	5-36
	16.7	200	WYSP - 200S12A		○	○	○					97× 192× 80	5-37
	25.0	300	WYSP - 300S12A		○	○	○	○	○	○	○	120× 190× 92	5-38
	50.0	600	WYSP - 600S12C		○	○	○	○	○	○	○	190× 200× 92	5-39
	100.0	1200	WYSP - 1200S12C		○	○	○	○	○	○	○	200× 300× 97	5-40
	125.0	1500	WYSP - 1500S12C		○	○	○	○	○	○	○	200× 300× 97	5-41

◆ **WYSP-SERIES**

SINGLE OUTPUT

OUTPUT VOLTAGE (V)	OUTPUT AMPS (A)	OUTPUT WATTS (W)	MODEL	INPUT VOLTAGE (V)	FUNCTION							DIMENSION W× H× D (mm)	PAGE	
					OC	OPP	V. SENS	R. C	CB	FAN	ALARM			
15	1.0	15	WYSP - 15S15B	AC 85 ~ 264	<input type="checkbox"/>							64× 97.5× 32	5-30	
	2.0	30	WYSP - 30S15B		<input type="checkbox"/>								79× 98× 37	5-31
	3.3	50	WYSP - 50S15B	AC85 ~ 132 / 170 ~ 264	<input type="checkbox"/>	<input type="checkbox"/>						83× 125× 40	5-32	
	5.0	75	WYSP - 75S15B		<input type="checkbox"/>	<input type="checkbox"/>							96× 135× 40	5-33
	6.7	100	WYSP - 100S15A		<input type="checkbox"/>	<input type="checkbox"/>	<input type="checkbox"/>						105× 205× 46	5-34
	8.0	120	WYSP - 120S15A		<input type="checkbox"/>	<input type="checkbox"/>	<input type="checkbox"/>						105× 205× 46	5-35
	10.0	150	WYSP - 150S15A		<input type="checkbox"/>	<input type="checkbox"/>	<input type="checkbox"/>						105× 205× 46	5-36
	13.3	200	WYSP - 200S15A		<input type="checkbox"/>	<input type="checkbox"/>	<input type="checkbox"/>						97× 192× 80	5-37
24	0.6	15	WYSP - 15S24B	AC 85 ~ 264	<input type="checkbox"/>							64× 97.5× 32	5-30	
	1.3	30	WYSP - 30S24B		<input type="checkbox"/>	<input type="checkbox"/>							79× 98× 37	5-31
	2.1	50	WYSP - 50S24B	AC85 ~ 132 / 170 ~ 264	<input type="checkbox"/>	<input type="checkbox"/>						83× 125× 40	5-32	
	3.1	75	WYSP - 75S24B		<input type="checkbox"/>	<input type="checkbox"/>							96× 135× 40	5-33
	4.2	100	WYSP - 100S24A		<input type="checkbox"/>	<input type="checkbox"/>	<input type="checkbox"/>						105× 205× 46	5-34
	5.0	120	WYSP - 120S24A		<input type="checkbox"/>	<input type="checkbox"/>	<input type="checkbox"/>						105× 205× 46	5-35
	6.3	150	WYSP - 150S24A		<input type="checkbox"/>	<input type="checkbox"/>	<input type="checkbox"/>						105× 205× 46	5-36
	8.3	200	WYSP - 200S24A		<input type="checkbox"/>	<input type="checkbox"/>	<input type="checkbox"/>						97× 192× 80	5-37
	12.5	300	WYSP - 300S24A		<input type="checkbox"/>	<input type="checkbox"/>	<input type="checkbox"/>	<input type="checkbox"/>	<input type="checkbox"/>	<input type="checkbox"/>	<input type="checkbox"/>	<input type="checkbox"/>	120× 190× 92	5-38
	25.0	600	WYSP - 600S24C		<input type="checkbox"/>	<input type="checkbox"/>	<input type="checkbox"/>	<input type="checkbox"/>	<input type="checkbox"/>	<input type="checkbox"/>	<input type="checkbox"/>	<input type="checkbox"/>	190× 200× 92	5-39
	50.0	1200	WYSP - 1200S24C		<input type="checkbox"/>	<input type="checkbox"/>	<input type="checkbox"/>	<input type="checkbox"/>	<input type="checkbox"/>	<input type="checkbox"/>	<input type="checkbox"/>	<input type="checkbox"/>	200× 300× 97	5-40
	62.5	1500	WYSP - 1500S24C		<input type="checkbox"/>	<input type="checkbox"/>	<input type="checkbox"/>	<input type="checkbox"/>	<input type="checkbox"/>	<input type="checkbox"/>	<input type="checkbox"/>	<input type="checkbox"/>	200× 300× 97	5-41
48	0.3	15	WYSP - 15S48B	AC 85 ~ 264	<input type="checkbox"/>							64× 97.5× 32	5-30	
	0.6	30	WYSP - 30S48B		<input type="checkbox"/>	<input type="checkbox"/>							79× 98× 37	5-31
	1.0	50	WYSP - 50S48B	AC85 ~ 132 / 170 ~ 264	<input type="checkbox"/>	<input type="checkbox"/>						83× 125× 40	5-32	
	1.6	75	WYSP - 75S48B		<input type="checkbox"/>	<input type="checkbox"/>							96× 135× 40	5-33
	2.1	100	WYSP - 100S48A		<input type="checkbox"/>	<input type="checkbox"/>	<input type="checkbox"/>						105× 205× 46	5-34
	2.5	120	WYSP - 120S48A		<input type="checkbox"/>	<input type="checkbox"/>	<input type="checkbox"/>						105× 205× 46	5-35
	3.1	150	WYSP - 150S48A		<input type="checkbox"/>	<input type="checkbox"/>	<input type="checkbox"/>						105× 205× 46	5-36
	4.2	200	WYSP - 200S48A		<input type="checkbox"/>	<input type="checkbox"/>	<input type="checkbox"/>						97× 192× 80	5-37
	6.3	300	WYSP - 300S48A		<input type="checkbox"/>	<input type="checkbox"/>	<input type="checkbox"/>	<input type="checkbox"/>	<input type="checkbox"/>	<input type="checkbox"/>	<input type="checkbox"/>	<input type="checkbox"/>	120× 190× 92	5-38
	12.5	600	WYSP - 600S48C		<input type="checkbox"/>	<input type="checkbox"/>	<input type="checkbox"/>	<input type="checkbox"/>	<input type="checkbox"/>	<input type="checkbox"/>	<input type="checkbox"/>	<input type="checkbox"/>	190× 200× 92	5-39
	25.0	1200	WYSP - 1200S48C		<input type="checkbox"/>	<input type="checkbox"/>	<input type="checkbox"/>	<input type="checkbox"/>	<input type="checkbox"/>	<input type="checkbox"/>	<input type="checkbox"/>	<input type="checkbox"/>	200× 300× 97	5-40
	31.3	1500	WYSP - 1500S48C		<input type="checkbox"/>	<input type="checkbox"/>	<input type="checkbox"/>	<input type="checkbox"/>	<input type="checkbox"/>	<input type="checkbox"/>	<input type="checkbox"/>	<input type="checkbox"/>	200× 300× 97	5-41

◆ **WYSP-SERIES**

DUAL OUTPUT

OUTPUT VOLTAGE (V)		OUTPUT AMPS (A)		OUTPUT WATTS (W)	MODEL	INPUT VOLTAGE (V)	FUNCTION							DIMENSION W× H× D (mm)	PAGE
CH1	CH2	CH1	CH2				OCP	OVP	V. SENS	R. C	CB	FAN	ALARM		
5	9	2.0	0.5	15	WYSP - 15D0509B	AC 85 ~ 264	○						79× 98× 37	5-42	
5	12	2.0	0.5		WYSP - 15D0512B		○								5-42
5	9	3.0	3.0	30	WYSP - 30D0509B	AC85~132 / 170~264	○	○					83× 125× 40	5-43	
5	12	3.0	1.2		WYSP - 30D0512B		○	○							5-43
5	24	3.0	0.6		WYSP - 30D0524B		○	○							5-43
5	9	5.0	5.0	50	WYSP - 50D0509B	AC85~132 / 170~264	○	○					96× 135× 40	5-44	
5	12	3.0	3.0		WYSP - 50D0512B		○	○							5-44
5	24	3.0	1.5		WYSP - 50D0524B		○	○							5-44
5	9	7.5	7.5	75	WYSP - 75D0509A	AC85~132 / 170~264	○	○					105× 205× 46	5-45	
5	12	5.0	5.0		WYSP - 75D0512A		○	○							5-45
5	24	3.0	2.5		WYSP - 75D0524A		○	○							5-45
12	12	0.7	0.5	15	WYSP - 15D12B	AC 85 ~ 264	○	○					79× 98× 37	5-42	
		2.0	2.0	30	WYSP - 30D12B		○	○					83× 125× 40	5-43	
		2.0	2.0	50	WYSP - 50D12B		○	○					96× 135× 40	5-44	
		3.1	3.1	75	WYSP - 75D12A		○	○					105× 205× 46	5-45	
15	15	0.5	0.5	15	WYSP - 15D15B	AC 85 ~ 264	○	○					79× 98× 37	5-42	
		1.6	1.6	30	WYSP - 30D15B		○	○					83× 125× 40	5-43	
		1.6	1.6	50	WYSP - 50D15B		○	○					96× 135× 40	5-44	
		2.5	2.5	75	WYSP - 75D15A		○	○					105× 205× 46	5-45	

◆ **WYSP-SERIES**

TRIPLE OUTPUT

OUTPUT VOLTAGE (V)			OUTPUT AMPS (A)			OUTPUT WATTS (W)	MODEL	INPUT VOLTAGE (V)	FUNCTION							DIMENSION W× H× D (mm)	PAGE
CH1	CH2	CH3	CH1	CH2	CH3				OCP	OVP	V. SENS	R. C	CB	FAN	ALARM		
5	12	-12	2	0.3	0.2	15	WYSP - 15T12B	AC 85 ~ 264	○						79× 98× 37	5-46	
5	15	-15	2	0.3	0.2	15	WYSP - 15T15B		○							5-46	
5	12	-12	3	1.0	0.3	30	WYSP - 30T12B	AC 85 ~ 264	○	○					83× 125× 40	5-47	
5	15	-15	3	0.8	0.2	30	WYSP - 30T15B		○	○						5-47	
5	12	-12	5	1.8	0.3	50	WYSP - 50T12B	AC85 ~ 132 / 170 ~ 264	○	○					96× 135× 40	5-48	
5	15	-15	5	1.4	0.3	50	WYSP - 50T15B		○	○						5-48	